

5th International Symposium on
Languages for Specific Purposes (ISLSP)
&
Centers for International Business Education and
Research (CIBER) Business Language Conference



**Taking Stock and Moving Forward:
LSP Theory, Method, Content, Curriculum, Collaboration**

March 5-7, 2020
UNC Charlotte Center City
Charlotte, NC



UNC CHARLOTTE
College of Liberal Arts & Sciences

Department of Languages & Culture Studies

CONFERENCE VENUE UNC Charlotte Center City

2nd Floor--Keynotes and Lunches
Auditorium Room 201
Atrium Room 256

9th Floor-Workshops, Sessions, Breaks
Room 901, 902, 904, 905, 906

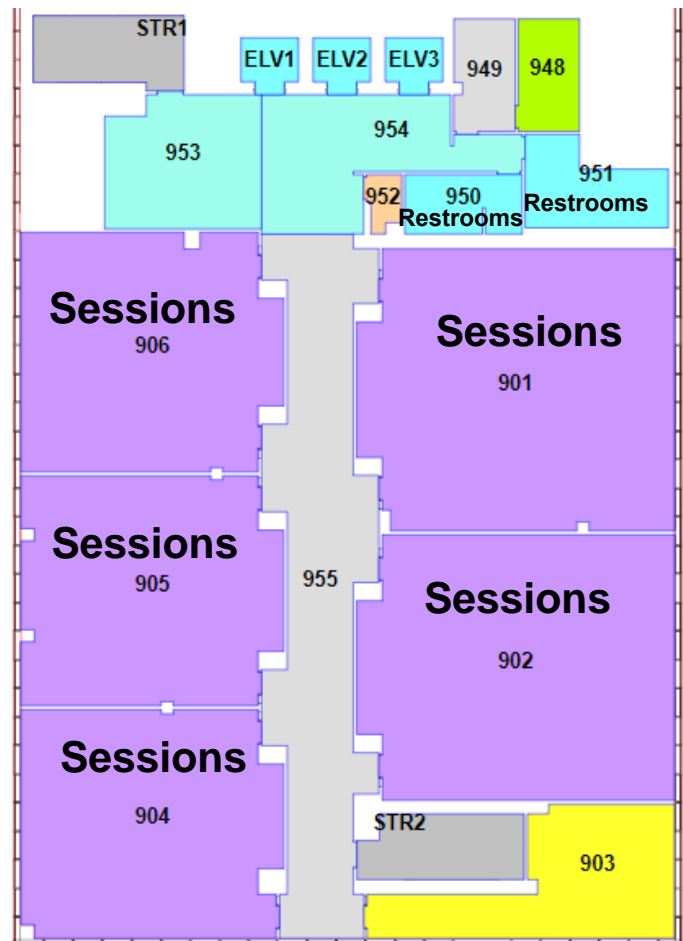
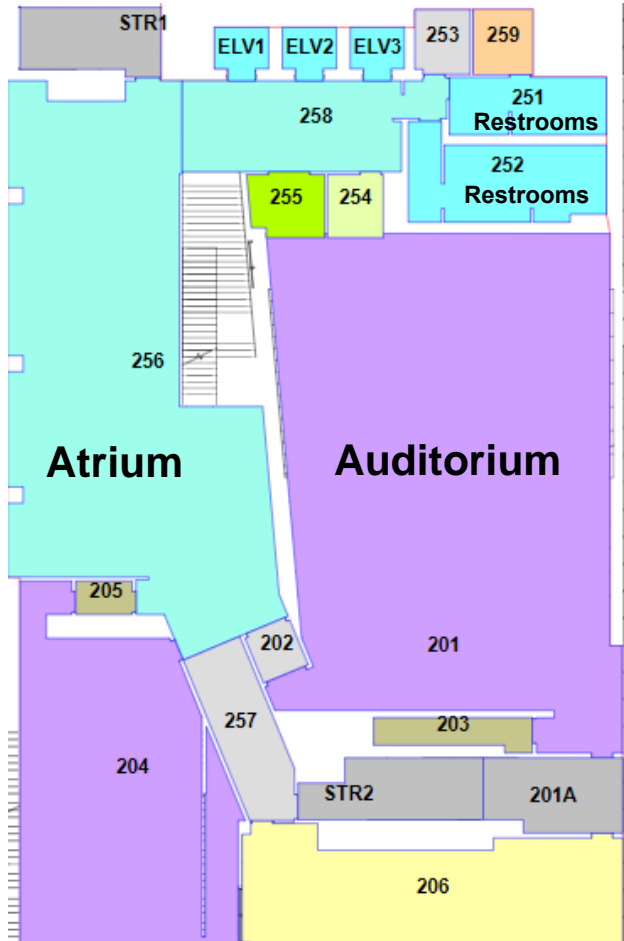

11th Floor—ISLSP Conference Room
Room 1106

3rd Floor – CIBER Conference Room
Room 302

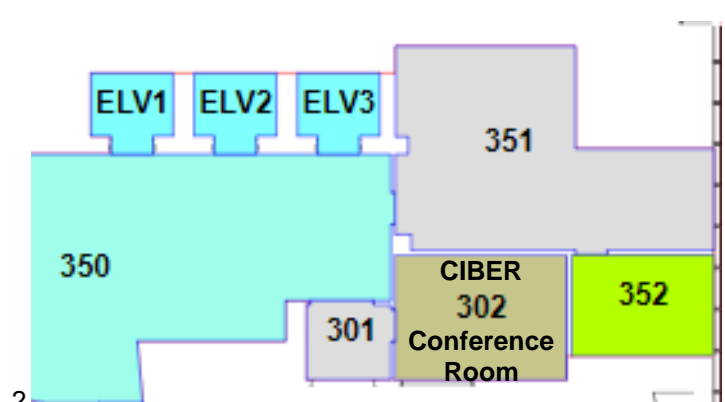
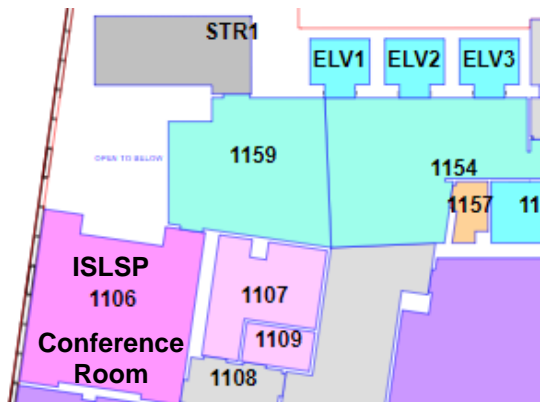

Table of Contents

Conference Venue.....	2
Welcome Message.....	4
Sessions at a Glance.....	5
Conference Program.....	8
Overview of Pre-Conference Workshops.....	16
Overview of Keynotes.....	18
Next Generation ISLSP Scholars 2020.....	20
CIBER Business Language Research & Teaching Awards	20
Presenters Index	21
Sponsors.....	24

Wi-Fi Information:

Please log into UNCC-Guest for free Wi-Fi in the Center City Building.



Welcome

5th International Symposium on Languages for Specific Purposes (ISLSP) & Centers for International Business Education and Research (CIBER) Business Language Conference

Dear Colleagues!

Welcome to the 5th International Symposium on Languages for Specific Purposes (ISLSP) and Centers for International Business Education and Research (CIBER) Business Language Conference, hosted by the University of North Carolina at Charlotte. This year's theme is *Taking Stock and Moving Forward: LSP Theory, Method, Content, Curriculum, Collaboration*.

On the occasion of its fifth biennial gathering, it is fitting that the ISLSP should "take stock" of what has transpired since its origins at the University of Alabama at Birmingham in 2012, and its accomplishments to date. At the same time, it is all about "moving forward" with the CIBERs, exploring LSP developments and possibilities as we travel together into the coming decade. The conference provides a forum for the community of LSP scholars, instructors, and administrators to share developments and innovation in LSP research, practice, and curriculum development, broadly considered.

On behalf of the local organizing committee, we thank our co-sponsors: 15 USDOE-funded CIBERs, the UNC Charlotte College of Liberal Arts and Sciences, Belk College of Business, College of Arts + Architecture, The Graduate School, the Office of International Programs, the University Career Center, Department of Languages and Culture Studies, Department of English, Department of Global Studies, the Latin American Studies program, and the Confucius Institute at UNC Charlotte. We also thank our sponsors Vista Higher Learning and the program in Interpreting and Translation Studies at Wake Forest University. We greatly appreciate the support of our

External Advisory Board: Drs. Carmen King de Ramírez, Barbara Lafford, Mary Long, Mary Risner, Lourdes Sánchez-López, and Sheri Spaine Long. We would like to accord special appreciation for their support to Dr. Nancy Gutierrez, Dean and Dr. Rich Leeman, Senior Associate Dean in the College of Liberal Arts and Sciences. We also thank Dr. Michèle Bissière, Chair, Ms. Carol Hartley, Business Services Coordinator, Dr. Bobby Hobgood, Director of the Language Resource Center, and Julia Geaney-Moore, Administrative Support Associate of the Department of Languages and Culture Studies. We are grateful for all of their work and support in preparing for a successful conference.

We also thank our amazing colleagues and students who are volunteering: Concepción Godev, Mónica Rodríguez-Castro, Enika Banerjee, Shaun Stone, Andrew Meyer, Samantha Roberts, Emily Edwards, Vanessa Wessling, Austin and Katherine McComas, Alexis Rose, Chrystele Lacroix, María García, Nashaly Ruíz-González, John E. Holmes, Karen Roman, Cameron Doyle and Julia Buchenau.

While your time is short here, we hope that, in addition to connecting with LSP colleagues, you will enjoy UNC Charlotte's Center City Campus and the city of Charlotte's energy, many attractions, and eateries.

Thank you so much for joining us this year!

Mike, Anabel, and Chris

Dr. Michael Doyle
Dr. Anabel Aliaga-Buchenau
Dr. Christopher D. Mellinger
Co-Chairs of 2020 ISLSP/CIBER

Sessions at a Glance

Thursday, March 5

Time	Event and Location	Event and Location
8:00am-5:00pm	Check-In and Exhibits (Lobby First Floor)	
8:30-9:00am	Continental Breakfast (9 th Floor Lobby)	
Session I 9:00-10:30am	Workshop 1 (Room 901) Integrating Translation and Interpreting into the Language Classroom	Workshop 2 (Room 902) Teaching World Languages for Specific Purposes (WLSP): Practical Strategies and Models for Integrating WLSP into the World Language Classroom
10:30-10:45am	Coffee Break (9 th Floor)	
Session I (cont.) 10:45am- 12:00pm	Workshop 1 cont. (Room 901) Integrating Translation and Interpreting into the Language Classroom	Workshop 2 cont. (Room 902) Teaching World Languages for Specific Purposes (WLSP): Practical Strategies and Models for Integrating WLSP into the World Language Classroom
12:00-1:00pm	Lunch (Atrium 2 nd Floor)	
Session II 1:00-2:30pm	Workshop 3 (Room 901) Heritage Language Learning in LSP Courses and Programs	Workshop 4 (Room 902) What do Employers Want?: Finding the Sweet Spot for Language and Culture Providers
2:30-2:45 pm	Coffee Break (9 th Floor)	
Session II (cont.) 2:45-4:00pm	Workshop 3 cont. (Room 901) Heritage Language Learning in LSP Courses and Programs	Workshop 4 cont. (Room 902) What do Employers Want?: Finding the Sweet Spot for Language and Culture Providers
4:30-5:30pm	Opening Keynote (Auditorium 2 nd Floor) "America's Languages, the Economy and 21 st Century Language Programs: How Curricula Must Meet Learners in Higher Education" Dr. Bill Rivers, Executive Director at Joint National Committee for Languages	
6:00-7:00pm	Welcome Reception (Holiday Inn Rooftop Terrace)	
7:00pm	Dinner on your own	

Sessions at a Glance

Friday, March 6

Time	Event and Location	Event and Location	Event and Location	Event and Location	Event and Location
8:00am-5:00pm	Check-In and Exhibits (Lobby First Floor)				
8:00-8:30am	Continental Breakfast (Atrium 2 nd Floor)				
8:30-9:30am	CIBER Keynote (Auditorium 2 nd Floor) "The Language Business: Challenges and Opportunities" Mr. David Utrilla, Honorary Consul to Peru in Utah				
Session I 9:45-11:00am	Panel 1 (Room 901) LSP and Program Development	Panel 2 (Room 902) Spanish for Healthcare	Panel 3 (Room 904) Spanish and Business	Panel 4 (Room 905) Preparing Global Professionals	Panel 5 (Room 906) Developing a Professional French Course
11:00-11:15am	Coffee Break (9 th Floor)				
Session II 11:15am-12:30pm	Panel 1 (Room 901) LSP and Online Environments	Panel 2 (Room 902) Spanish for Healthcare and Service Professions	Panel 3 (Room 904) Teaching Practices	Panel 4 (Room 905) LSP Curricular Considerations	Panel 5 (Room 906) Translation & Interpreting Across the Spanish Curriculum
12:45-1:45pm	Lunch (Atrium 2 nd Floor) Luncheon Speaker Mr. Klaus Becker, Honorary Consul to Germany in Charlotte				
Session III 2:00-3:15pm	Panel 1 (Room 901) LSP and Curricular Considerations	Panel 2 (Room 902) LSP and Healthcare	Panel 3 (Room 904) LSP and Course Design	Panel 4 (Room 905) LSP and Study Abroad	Panel 5 (Room 906) Editors' Roundtable (Journal Articles)
3:15-3:30pm	Coffee Break (9 th Floor)				
Session IV 3:30-4:45pm	Panel 1 (Room 901) LSP and Instructional Design	Panel 2 (Room 902) LSP and Intercultural Competency	Panel 3 (Room 904) World Languages for Military Purposes	Panel 4 (Room 905) Experiential Learning	Panel 5 (Room 906) LSP and Materials Development
5:30-6:30pm	CIBER Reception and Awards (Holiday Inn Ballroom)				
6:30pm	Dinner on your own				

Sessions at a Glance

Saturday, March 7

Time	Event and Location	Event and Location	Event and Location	Event and Location	Event and Location
8:00am-5:00pm	Check-In and Exhibits (Lobby First Floor)				
8:00-8:30am	Continental Breakfast (Atrium 2 nd Floor)				
8:30-9:30am	ISLSP Keynote (Auditorium 2 nd Floor) “The State of LSP in American Higher Education: Reflecting on the First Decade of the ISLSP and Moving Forward” Dr. Lourdes Sánchez-López, University of Alabama Birmingham				
Session I 9:45-11:00am	Panel 1 (Room 901) LSP and Literacy	Panel 2 (Room 902) Business, Culture and Language: A Chinese Perspective	Panel 3 (Room 904) LSP and Technology	Panel 4 (Room 905) Bridging the Gap Between the Language Service Industry and Academia	Panel 5 (Room 906) Assessment and Evaluation in LSP: Beyond Exams and Papers
11:00-11:15 am	Coffee Break (9 th Floor)				
Session II 11:15am - 12:30pm	Panel 1 (Room 901) LSP and Ethics	Panel 2 (Room 902) LSP and Course/Material Design	Panel 3 (Room 904) LSP and Language Learning	Panel 4 (Room 905) LSP and Internships	Panel 5 (Room 906) LSP Publishing and Scholarship
12:45-1:45pm	Lunch (Atrium 2 nd Floor)				
Session III 2:00-3:15pm	Panel 1 (Room 901) LSP and Terminology	Panel 2 (Room 902) LSP and Course Design	Panel 3 (Room 904) LSP and Study Abroad/ Exchange Programs	Panel 4 (Room 905) LSP and Service Learning	Panel 5 (Room 906) Editors' Roundtable (Edited Volumes and Books)
3:15-3:30pm	Coffee Break (9 th Floor)				
Session IV 3:30-4:45pm	Panel 1 (Room 901) LSP and Interdisciplinarity	Panel 2 (Room 902) Sustaining the Major: Spanish for the Professions in the Post-Globalization Era	Panel 3 (Room 904) LSP and Legal Contexts	Panel 4 (Room 905) Curricular Innovations in LSP: Spanish, French, Japanese	Panel 5 (Room 906) LSP Instructional Strategies
5:00-6:00pm	General Session: ISLSP Business Meeting (Auditorium 2 nd Floor)				

Detailed Program

Thursday, March 5

8:00 am-5:00 pm Check-In (Lobby)

8:30-9:00 am Continental Breakfast (9th Floor)

Session I – 9:00 am-1:00 pm with 10:30-10:45 am Coffee Break (9th Floor)

Workshop I (Room 901)
Integrating Translation and Interpreting into the Language Classroom
Facilitator: Chris Mellinger, UNC Charlotte

Workshop II (Room 902)
Teaching World Languages for Specific Purposes (WLSP): Practical Strategies and Models for Integrating WLSP into the World Language Classroom

Facilitator: Diana Ruggiero, University of Memphis

12:00-1:00 pm Lunch (Atrium 2nd Floor)

Session II – 1:00-4:00 pm with 3:30-3:45 pm Coffee Break (9th Floor)

Workshop III (Room 901)
Heritage Language Learning in LSP Courses and Programs
Facilitator: Laura Gasca Jiménez

Workshop IV (Room 902)
What do Employers Want?: Finding the Sweet Spot for Language and Culture Providers
Facilitator: David Victor

Opening Keynote-4:30-5:30 pm (Auditorium 2nd Floor)

“America’s Languages, the Economy and 21st Century Language Programs: How Curricula Must Meet Learners in Higher Education”

Dr. Bill Rivers, Executive Director at Joint National Committee for Languages

6:00-7:00 pm Welcome Reception (Holiday Inn Rooftop Terrace)

Followed by dinner on your own

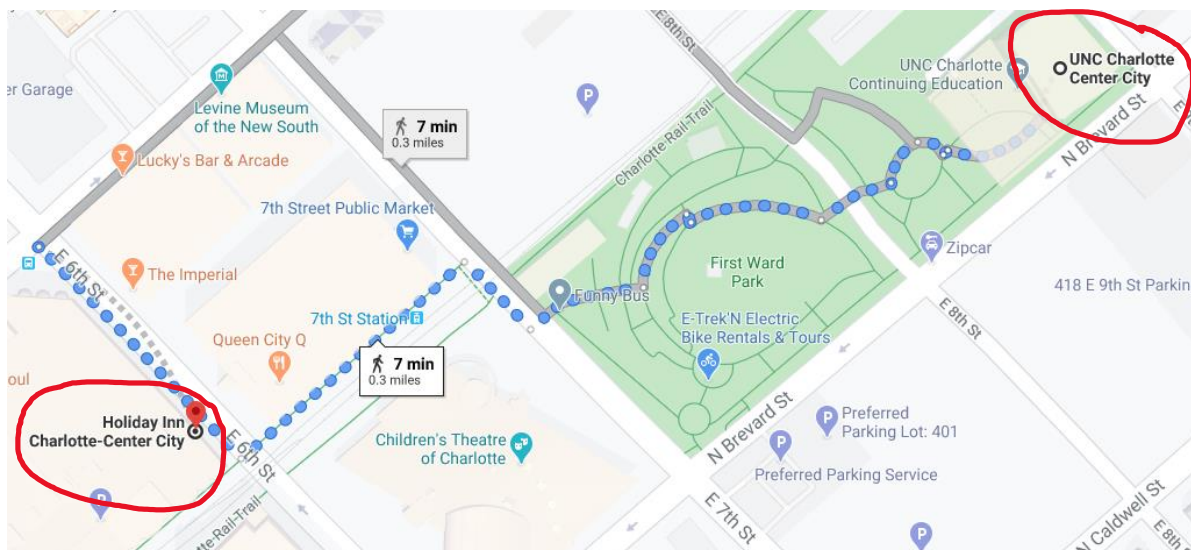

Friday, March 6

8:00 am-5:00 pm Check-In (Lobby)
8:00-8:30 am Continental Breakfast (9th Floor)

CIBER Keynote -- 8:30-9:30 am (Auditorium 2nd Floor)

“Language Business: Challenges and Opportunities”

David Utrilla, Honorary Consul to Peru in Utah

Session I -- 9:45-11:00 am

Panel 1 (Room 901) -- LSP and Program Development

Moderator: Mónica Rodríguez-Castro

“SSP and Human Development and Family Studies Certificate” Andrea Purdy Marishel Díaz-Levy Tatiana Nekrasova-Beker	“Integrative Curricular Design: A Minor in Spanish for the Health Professions for College Students” María E. Pérez	“Revitalizing Business French in a Small French Program: Lessons Learned” Alisha Reaves
---	---	--

Panel 2 (Room 902) -- Spanish for Healthcare

Moderator: Glenn Martinez

“Implementation of a Spanish Language Track for Family Medicine Residents” Karol Hardin	“Spanish Speaking Patients' Insights on Improving Communication in Healthcare” Dalia Magaña	“Body Language Awareness: Teaching Medical Spanish Interpreting” Diana Ruggiero, Joanna Orozco Mariele Cunha de Souza Jonathan Jones-Edwards
--	--	---

Panel 3 (Room 904) -- Spanish and Business

Moderator: Erika Banerjee

“Backward Design for Business Language Instruction” Geraldine Lebaudy	“Preparing Financial Analysts for the Globalized Market: Curricular and Language Considerations for Careers in Finance” Thomas Hanson	“A Spanish for Business Curriculum in a Business University” Christian Rubio
--	--	---

Panel 4 (Room 905) -- Preparing Global Professionals: “Building Languages and Cultures for Professions” at Iowa State University

Moderator: Chad Gasta

“LCP Beyond the Classroom Walls: Experiential Learning Opportunities” Megan Myers	“Bridging Research and Practice: Harnessing the Power of Motivation Science to Understand Language Recruitment and Retention” Charles Nagle	“Engaging Constituencies: Recruitment and Retention, Outreach, and Program Promotion” Jennifer Musgrove
--	--	--

Panel 5 (Room 906) -- Developing a Professional French Language Course

Moderator: Emily Edwards

“The Embassy of France’s Support of the Development of French on Professional Purposes in the U.S.” Hélène Bouche Mathieu Ausseil	“Paris Ile-de-France Chamber of Commerce and Industry’s Expertise and Business French Diplomas” Romaine Deveaux Alexandre Holle	“Opening a French for Professional Purposes Course: Case Study” E. Nicole Meyer
---	---	--

11:00-11:15 am - Coffee Break (9th Floor)

Session II -- 11:15 am-12:30 pm

Panel 1 (Room 901) -- LSP and Online Environments

Moderator: Mónica Rodríguez-Castro

<p>“Teaching Specialized Translation Online: The Potential of Discussion Forums” Jeffrey Killman</p>	<p>“Virtual Collaboration: Lessons Learned Among Students from Europe and North America” Regina Brautlacht Kristi Julian Wendi Hulme Lurdes Martins</p>	<p>“Developing a Blended/Online Business Language Course for Career Readiness in the 21st Century” Hei Sook Yoo *BLRT Award Winner*</p>
--	---	--

Panel 2 (Room 902) -- Spanish for Healthcare and Service Professions

Moderator: Samantha Roberts

<p>“Teaching Spanish for Health-Care and Human Services: Questioning Epistemologies and Power Dynamics” Natalia Santamaria Laorden</p>	<p>“Spanish for Medical Professions: A Longitudinal Assessment of a Health-Related Community Interview” Allyson Irom Julio César Aguilar</p>	<p>“Educating the Solutionary Generation: A Humane Education Approach to Language for Specific Purposes” Stacy Hoult-Saros</p>
--	--	--

Panel 3 (Room 904) -- Teaching Practices

Moderator: Enika Banerjee

<p>“Evidence-centered Curricular Design and Classroom Practice: Domain Analysis in LSP Research and Teaching” Darcy Lear Verónica Moraga</p>	<p>“The Learner’s LSP Dictionary to Gain Subject Field Knowledge and Develop Language Skills” Tamara Petrashova</p>	<p>“Developing Interdisciplinary and Intercultural Project-based Curriculum for Spanish for Medical/Healthcare Courses” Graciela Helguero-Balcells José María Balcells</p>
--	---	--

Panel 4 (Room 905) -- LSP Curricular Considerations

Moderator: Emily Edwards

<p>“The Flip Side of Teaching: Recruitment and Retention – Professional Preparation through a Pre-service L2 Methods Course” Frédérique Grim</p>	<p>“Business Certificate and Internships: How to Prepare German Majors for the Business World” Angela Jakeway</p>	<p>“Taking Stock and Moving Forward with LSP as Dual Language Immersion Programs Grow” Sean Hill</p>
--	---	--

Panel 5 (Room 906) -- Translation and Interpreting Across the Spanish Curriculum

Moderator: Diana Ruggiero

<p>“Spaces for the Teaching of Translation and Interpreting in the Spanish Language Curriculum” Laura Gasca Jiménez</p>	<p>“An Open-Access Textbook for Spanish Community Translation and Interpreting” Laura Kanost</p>	<p>“Healthcare Interpreting Competencies among Spanish Heritage Language Learners” Glenn Martinez</p>
---	--	---

12:45-1:45 pm Lunch (Atrium 2nd Floor)

Luncheon Speaker

Klaus Becker, Honorary Consul of the Federal Republic of Germany in North Carolina

Session III – 2:00-3:15 pm

Panel 1 (Room 901) -- LSP and Curricular Considerations

Moderator: Mónica Rodríguez-Castro

<p>“Program Articulation in U.S. Translator and Interpreting Training” Julio Ciller</p>	<p>“How Access, Alignment and Agility Support LSP Programme Development in Spanish and Mandarin” Beverly-Anne Carter</p>	<p>“Spanish for STEM in U.S. Higher Education: Historical and Current Approaches” Oscar Pérez</p>
---	--	---

Panel 2 (Room 902) -- LSP and Healthcare

Moderator: Erika Banerjee

<p>“Patient’s Perceptual Judgment: How Accent Defines the Level of Reliability with the Health Professional” Paloma Pinillos Chavez</p>	<p>“Introducing the Nahuatl Language into Rural Health Care Services: Advances of the Participatory-Action Research in Sierra Norte de Puebla” Gregory Haimovich</p>	<p>“Portrayal of Health and Business Topics in Film” Graciela Tissera</p>
---	--	---

Panel 3 (Room 904) -- LSP and Course Design

Moderator: Shaun Stone

<p>“Researching Disciplinary-specific Practices in Engineering Discourse: A Phrase-Frame Approach” Tatiana Nekrasova-Beker and Anthony Becker</p>	<p>“Business Arabic Training and Education” Ghayda Al-Ali</p>	<p>“‘Genre chain’ and the Design of a Russian for Academic Purposes Course” Svetlana Korshunova</p>
---	---	---

Panel 4 (Room 905) -- LSP and Study Abroad

Moderator: Audrey Chery

<p>“Studying Abroad: Does it Matter if Students can’t Articulate What They’ve Learned?” Kacy Peckenpaugh</p>	<p>“French for Fashion and the Diplôme de Français Professionnel: a Model for Second Language Immersion Abroad” Paola Buckley</p>	<p>“Medical Spanish Abroad: Teaching Linguistic Flexibility in Patient Interactions” Paige Barton</p>
--	---	---

Panel 5 (Room 906) -- Editors' Roundtable (Journal Articles)

Moderator: Michael Scott Doyle

<p>Participating Editors</p> <p>Jennifer Brady Sheri Spaine Long Michael Scott Doyle Christopher D. Mellinger Barbara Lafford</p>	
---	--

3:15-3:30 pm - Coffee Break (9th Floor)

Session IV -- 3:30-4:45 pm

Panel 1 (Room 901) -- LSP and Instructional Design

Moderator: Xinyue Lu

<p>“Implementing Translanguaging Strategies in a Business Chinese Class” T. Dori Huang</p>	<p>“Effects of Backward Instructional Design in an Advanced Business Chinese Course” Wei Lai *BLRT Award Winner*</p>	<p>“English for Specific Purposes - Training course for the TOEFL and the IELTS writing tasks” Priscila Medrado Costa</p>
--	---	---

Panel 2 (Room 902) -- Intercultural Competency

Moderator: Erika Banerjee

<p>“Integrating Intercultural Competency in LSP Programs” Shannon Zeller Maura Velazquez-Castillo</p>	<p>“Using Case Studies at the Intermediate Level: Intercultural Competence within the German-speaking Countries” Amanda Sheffer</p>	<p>“Developing Intercultural Competence in the Business World: A Needs Analysis” Sergio Adrada Rafael</p>
---	---	---

Panel 3 (Room 904) -- World Languages for Military Purposes

Moderator: Dieter Waldvogel

<p>“Foreign Language Education and National Security: The State of Foreign Language Education in the U.S. Military” Dieter Waldvogel</p>	<p>“Using the US Military Academy’s Department of Foreign Language to Win in a Complex World” Capt. William “Bill” Sack & Maj. George Gurrola</p>	<p>“Language for Specific Purposes: Portuguese Language for Military and Foreign Affairs” Ismenia De Souza</p>
--	---	--

Panel 4 (Room 905) -- Experiential Learning

Moderator: Barbara Lafford

<p>“UF in Cusco (Peru): Experiential Learning for the Health Professions” Gregory Moreland</p>	<p>“Building Bridges Between the Hispanic Community and the Legal and Medical Spanish Students: Some Examples of Service Learning in LSP Classes” Anna Alsina Naudi & Paloma Moscardo</p>	<p>“Including Foreign Language Entrepreneurship in the Spanish for Business Curriculum” Maida Watson</p>
--	---	--

Panel 5 (Room 906) -- LSP and Materials Development

Moderator: Margaret Gonglewski

<p>“Global French (for Specific Purposes) Studies” Deborah Reisinger</p>	<p>“Developing Course Materials for the LSP Classroom: A Text-Based Approach” Christopher D. Mellinger</p>	<p>“Task-based LSP Materials Development” Kichan Park</p>
--	--	---

5:30-6:30 pm CIBER Reception and Awards Ceremony (Holiday Inn Ballroom)**Saturday, March 7****8:00 am-5:00 pm Check In (Lobby)****8:00-8:30 am Continental Breakfast (9th Floor)****ISLSP Keynote -- 8:30-9:30 am (Auditorium 2nd Floor)**

**“The State of LSP in American Higher Education:
Reflecting on the First Decade of the ISLSP and Moving Forward”**

Dr. Lourdes Sánchez-López, Founder of ISLSP, University of Alabama at Birmingham

Session I -- 9:45-11:00 am

Panel 1 (Room 901) -- LSP and Literacy

Moderator: Xinyue Lu

"A Multiliteracies Approach for the LSP Classroom: Preparing Your Students for Real-world Contexts" Heather McCoy	"Kinderchat as a New Literacy Practice" Asiye Demir	"Incorporating Sustainability Literacy in a Spanish for Healthcare Course: A Curricular Innovation" Marianne Verlinden
--	--	---

Panel 2 (Room 902) -- Business, Culture and Language: A Chinese Perspective

Moderator: Yongling Gorke

Yongling Gorke, Michael Young, Meiru Liu
--

Panel 3 (Room 904) -- LSP and Technology

Moderator: Jeffrey Killman

"Social Media Digital Marketing Integration into Language for Business Courses " Sibel Crum *BLRT Award Winner*	"Social Networks in the LSP Classroom: Using YouTube and LinkedIn to Promote an International and Professional Online Presence" Nathalie Ciesco
---	--

Panel 4 (Room 905) -- Bridging the Gap Between the Language Service Industry and Academia: Connecting Students to Employers

Moderator: Mary Risner

"Introduction to ALC Bridge Career Connection Opportunities" Mary Risner	"Exploring Careers in the Language Industry" Steve Lank	"Course Models Preparing Students for Careers in the Language Industry" Adam Wooten
---	--	--

Panel 5 (Room 906) -- Assessment and Evaluation in LSP: Beyond Exams and Papers

Moderator: Carmen Perez-Muñoz

"Epic Finale vs. Final Exam: One Experience in Business French" Amanda Vincent	"YouTube for LSP: A Logical Pairing" Audra Merfeld-Langston	"Make LSP Assessment More Real" Qiaona Yu	"Real-life Experiences for Medical Spanish Assessment" Carmen Pérez-Muñoz
---	--	--	--

11:00-11:15 am - Coffee Break (9th Floor)

Session II -- 11:15 am-12:30 pm

Panel 1 (Room 901) -- LSP and Ethics

Moderator: Laura Gasca Jiménez

"Social Justice and Ethics in an Advanced Business Spanish Course" Jennifer Brady	"A Case for French for Humanitarian Response in the Curriculum" Catherine Daniélou	"Developing Ethics Standards for Translation in Global News: A Case Study" Allison Braden
--	---	--

Panel 2 (Room 902) -- LSP and Healthcare

Moderator: Samantha Roberts

"Implementing Scenario-based and Project-based Learning in Spanish for the Professions" Mónica Rodríguez-Castro Maria Mahaffey	"English for Tourism and Hotel Industries for Secondary School in Jordan" Duaa Makhoul
--	---

Panel 3 (Room 904) -- LSP and Language Learning

Moderator: Emily Edwards

“Building Language Proficiency in Business Spanish Courses” Craig Bergeson	“Reading for Academic Purposes in Intermediate Foreign Language” Concepción Godev
---	--

Panel 4 (Room 905) -- LSP and Internships

Moderator: Concepción Godev

“An internship-oriented LSP program for Chinese: What can teachers do and what they can’t?” Zhongqi Shi Shuai Li	“Using Adaptive Learning to Promote Intercultural Competence and Industry-Specific Language Skills in an Online Internship Course” Shelly Wyatt Maria Mollica Redmon	“International Business Mentorships: A Collaboration between the Spanish Department and the Darden School of Business at UVA” Esther Poveda Moreno Paula Sprague
--	---	--

Panel 5 (Room 906) -- LSP Publishing and Scholarship

Moderator: Audrey Chery

“Moving Forward in LSP Scholarship: The Relaunch of Global Business Languages Journal” Margaret Gonglewski Mohssen Esseesy	“Preparing Future Educators: The Role of Transferable Skills in World Languages for Specific Purposes” Carmen King de Ramírez Barbara Lafford
--	---

12:45-1:45 pm Lunch (Atrium 2nd Floor)**Session III -- 2:00-3:15 pm****Panel 1 (Room 901) -- LSP and Terminology**

Moderator: Mónica Rodríguez-Castro

“Elevator Terms and Technology: An Examination of a 1910 Multilanguage Technical Dictionary” Lee Gray	“An Updated View of Multi-Word Terms for LSP” Diego Burgos	“Feminine Slang in the 21st Century” Hannah Hunt
--	---	---

Panel 2 (Room 902) -- LSP and Course Design

Moderator: Shaun Stone

“Focusing on Doctor-Patient Conversations: A Curriculum for Medical Chinese” Meng Yeh Liang Fu	“Japanese Language Communication for Japanese Business” Erika Banerjee
--	---

Panel 3 (Room 904) -- LSP and Study Abroad/Exchange Programs

Moderator: María García

“An Interdisciplinary Study Abroad: A Collaborative Endeavour” Félix Vásquez	“Ethnographic Learning in a Study Abroad Business Chinese Program: Developing Learners’ Intercultural Competence” Xinyue Lu	“Business Spanish and the Interconnected World.” U. Theresa Zmurkewycz
---	--	---

Panel 4 (Room 905) -- LSP and Service Learning

Moderator: Lottie Baker

“Taking an Introductory Legal Spanish Class Live: The Process and Results of Incorporating a Service-Learning Component” Lisa Huempfer	“Innovative Curriculum: Language-Learning for a Specific Purpose—Spanish for Christian Ministry/Service Learning” Joan Barrett
---	---

Panel 5 (Room 906) -- Editors' Roundtable (Edited Volumes and Books)

Moderator: Michael Scott Doyle

Participating Editors

Lourdes Sánchez-López Mary Risner
Mary Long Concepción Godev
Carmen King de Ramírez

3:15-3:30 pm - Coffee Break (9th Floor)

Session IV -- 3:30-4:45 pm

Panel 1 (Room 901) -- LSP and Interdisciplinarity

Moderator: David Victor

"Cross-disciplinary Collaboration: Cornerstone to LSP Success" Margaret Gonglewski Anna Helm	"Translation and Memory: Memories from Mauthausen (Italian-English)" Daniela Cunico dal Pra	"Effecting Change through LSP Courses at the Grassroots Level" Sandhya Shanker Isaac Sarver
--	--	---

Panel 2 (Room 902) -- Sustaining the Major: Spanish for the Professions in the Post-Globalization Era

Moderator: Jennifer Brady

"Uniting Domains; Reviving the Canon" Mary K. Long	"Spanish for Business in the Post-Globalization Era" Karen Malcolm	"Writing Across Difference: A Dialogic Approach to Teaching Advanced Rhetoric and Composition" Anne Becher
---	---	---

Panel 3 (Room 904) -- LSP and Legal Contexts

Moderator: Shaun Stone

"Language Teaching in Southeast Asian Government Law Enforcement Academies: Meeting Multiple Demands for English" Lottie Baker	"Legal Language in the Mexican Criminal Law Context" Eleonora Lozano	"Laying the Groundwork for Success: Using Needs Analysis to Create a Community College Criminal Justice Spanish for Specific Purposes course" Stacy Amling
---	---	---

Panel 4 (Room 905) -- Curricular Innovations in LSP: Three Examples from Clemson University's Programs in Spanish, French and Japanese

Moderator: J. Lee Ferrell

"Blending LSP with the Health Humanities in a French for Health Program" Kelly Digby Peebles	"Combining Business Case Studies with Mock Product Proposals in a Japanese for Business Class" Jae DiBello Takeuchi	"Project-based Learning in a Business Spanish Class" Andrea Naranjo
---	--	--

Panel 5 (Room 906) -- LSP Instructional Strategies

Moderator: Audrey Chery

"Task Based Learning through the Business Case in French for the Professions" Cynthia Jones	"I'd never before thought of globalization as anything but good': Decentering Perspectives in the Business French Course" Isabelle Drewelow
--	--

5:00-6:00 pm General Session ISLSP Business Meeting (Auditorium 2nd Floor)

We are very pleased to announce that the 6th ISLSP-CIBER Business Language Conference in 2022 will be hosted by the University of Chicago. The contact person is Dr. Darcy Lear (darcylear@gmail.com). Stay tuned for more information in future months!

Overview of Workshops

Workshop 1 (Thursday, 9:00 am-12:00 pm, Room 901)

Integrating Translation and Interpreting into the Language Classroom **Dr. Christopher D. Mellinger, UNC Charlotte**

This interactive, hands-on workshop will provide participants with a range of activities, strategies, and techniques to integrate translation and interpreting (T&I) into existing general language courses as well as courses dedicated to language for specific purposes. The workshop will focus on research-based pedagogy that allows teachers to enhance the learning experiences of students in line with best practices. Examples will be provided from a range of languages, with potential opportunities to include T&I in relation to language use in legal, healthcare, social work, business, and community settings. The first half of the workshop will be dedicated to written translation, while the second half will focus on oral interpreting. Specific technology tools and software will be presented that can be incorporated into the language classroom. Particular emphasis will be placed on developing standalone activities and modules that can be quickly integrated into current course offerings. These activities aim to improve language proficiency and cultural awareness, and to provide students the opportunity to explore translation and interpreting as a profession. *The workshop is non-language-specific, and participants are welcome to participate from any language.*



Workshop 2 (Thursday, 9:00 am-12:00 pm, Rom 902)

Teaching World Languages for Specific Purposes (WLSP): Practical Strategies and Models for Integrating WLSP into the World Language Classroom **Dr. Diana Ruggiero, University of Memphis**

This hands-on workshop invites participants of all disciplinary backgrounds to learn about the pedagogy of world languages for specific purposes (WLSP). An inter- and multidisciplinary field, WLSP draws upon yet transcends the traditional disciplinary boundaries of linguistics, literature, and cultural studies in the teaching of language within and for specific contexts and purposes. The demand for courses and programs in WLSP is growing across the nation and meeting this need requires that more language educators and graduate students be trained in WLSP pedagogy. To this end, workshop participants will learn approaches such as significant learning and community service learning as well as practical teaching strategies and models in WLSP that they can integrate into existing or new courses. Among the topics addressed are learning objective alignment, lesson planning, classroom activities, assignment and assessment design, and teaching resources. Although the examples used will draw from Spanish language and culture courses, the ideas and examples are transferable to other world language areas. Teachers of all languages and of all learning levels are welcome to attend. We will create a sample activity for use in your next class or re-create one you already have.



Workshop 3 (Thursday, 1:00-4:00 pm, Room 901)

Heritage language learning in LSP courses and programs

Dr. Laura Gasca Jiménez, Fairfield University

This hands-on, interactive workshop will offer pedagogical and curricular considerations for language for specific purposes (LSP) courses and programs in the United States through the exploration of the intersections of LSP and heritage language (HL) education. Particular emphasis will be placed on responding to the needs of opportunities of HL learners in LSP courses and programs. Likewise, it will explore recent plurilingual and interdisciplinary approaches that have emerged in language education and their potential impact on LSP and HL education. Participants will be involved in a wide range of activities, covering different languages, which will allow them to recognize the challenges and opportunities of HL learners in LSP courses and programs. They will have the opportunity to develop activities directed at HL learners in undergraduate and graduate LSP courses. Similarly, they will reflect on how to adapt those activities for mixed contexts, that is, courses with second language and HL learners. The first half of the workshop will be dedicated to exploring the connections between LSP and heritage languages, while the second half will focus on best practices for LSP teaching and curricular development. *The workshop is non-language-specific, and participants are welcome to participate from any language.*



Workshop 4 (Thursday, 1:00-4:00 pm, Room 902)

What do Employers Want? Finding the Sweet Spot for Language and Culture Providers

Dr. David A. Victor, Eastern Michigan University

This workshop breaks down the skill sets identified in the Bloomberg Job Skills report, highlighting those skills that language and culture instructors can provide. The report charts skills into a matrix of those skills that hiring executives view as less and more commonly taught and less and more commonly desired. The workshop helps language and culture instructors to identify which skills instructors may wish to downplay (less desired) and which they should emphasize, namely

- Reinforcement skills (those that employers identify as more commonly taught and more desired), and
- Sweet spot skills (those that employers identify as less commonly taught and more desired),



The workshop then works with instructors on how to market their emphasized skills to the business community at large and to their own professional schools (business, engineering/technology, law, medicine, nursing) so that they can help others recognize their value-added to employers.

Overview of Keynote Speakers

Opening Keynote (Thursday, 4:30-5:30 pm Auditorium 2nd Floor)

“America’s Languages, the Economy, and 21st Century Language Programs: How Curricula Must Meet Learners in Higher Education”

Dr. Bill Rivers, Executive Director at Joint National Committee for Languages

Dr. Rivers has more than 25 years’ experience in culture and language for economic development and national security, with publications in second and third language acquisition research, proficiency assessment, program evaluation, and language policy development and advocacy. He is the immediate past and founding Chair of ASTM Technical Committee F43, Language Services and Products and chairs the U.S. Technical Advisory Group to ISO Technical Committee 232, Education and Learning Services. He serves as a member of the America’s Languages Working Group of the American Academy of Arts and Sciences, and is an honorary member of the Association of Language Companies. Before joining JNCL-NCLIS, he served as Chief Scientist at Integrated Training Solutions, Inc., a small business in Arlington, Virginia, where he focused on strategic planning, management, and advanced technologies for language and culture programs in the public sector. While at ITS, he served in a contractor role as the Chief Linguist of the National Language Service Corps. Prior to working at ITS, he was a founding member of the Center for Advanced Study of Language (CASL) at the University of Maryland, and was a staff member of the National Foreign Language Center at the University of Maryland from 1994 to 2003, leaving NFLC as Assistant Director. During his career, Dr. Rivers has also taught Russian (beginning through advanced), language policy, and second language acquisition at the University of Maryland, worked as a freelance interpreter and translator, and conducted field work in Kazakhstan, where he regularly returns to teach at several universities. He received his PhD in Russian from Bryn Mawr College and his MA, BA, and BS (Aerospace Engineering) from the University of Maryland. He speaks Russian and French.



CIBER Keynote (Friday, 8:30-9:30 am Auditorium 2nd Floor)

“Language Business: Challenges and Opportunities”

David Utrilla, Honorary Consul to Peru in Utah

David Utrilla studied international business and economics in Peru and in the USA. In 1995 he founded U.S. Translation Company and currently serves as its CEO. He and his company have been given multiple awards including Utah’s Best of State, listed six times in the Inc. 500/5000 for fastest growing companies in America, Mountain West Capital Network’s top 100 fastest growing companies in Utah, and the Small Business Person of the Year by the SBA. He has completed executive programs at Harvard Business School and Stanford University and been a speaker at the largest language localization world conferences LOCWorld, GALA and ALC. He has been the recipient of multiple awards from universities, chambers of commerce and the State of Utah for his entrepreneurial success and contributions to the community. He chairs and is a member of thirteen boards of directors, including financial institutions, universities, nonprofits, and international organizations. In 2009 he was appointed by the President of Peru as the Honorary Consul of Peru in Utah. He currently holds this position and is also the President of the Utah Consular Corp.



Luncheon Speaker (Friday, 12:45-1:45 pm, Atrium 2nd Floor)

Klaus E. Becker, Honorary Consul of the Federal Republic of Germany in North Carolina

Klaus Becker was born in Marburg in 1953, grew up in Germany where he studied business and national economics and has a master's degree from Ruhr-Universität in Bochum. Since 1979, he has lived in Charlotte, North Carolina, where he has been entrepreneurially active in the international steel trade for the past 40 years. He presided over the Charlotte World Trade Association in the mid-nineties and was President of the German-American Chamber of Commerce in North Carolina for seven years. In January of 2014, he was appointed Honorary Consul of the Federal Republic of Germany for western North Carolina. In this function, he founded The N.C. Zeitgeist Foundation which coordinates his consular activities. It is one goal of the Foundation to put Charlotte and surroundings on the political maps of the German institutions in Washington, Berlin and the German States. Further, the Foundation offers a wide array of aspects of German life to Charlotte and the region in artistic and cultural, journalistic and political, as well as historic and sports-related aspects (Bayern München and Borussia Dortmund played in Charlotte solely upon invitation of The N.C. Zeitgeist Foundation).

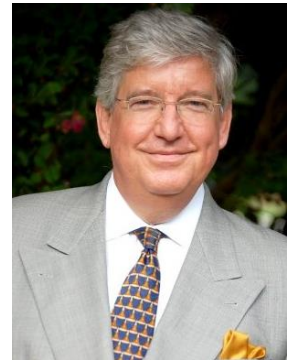

ISLSP Keynote (Saturday, 8:30-9:30 am, Auditorium 2nd Floor)

“The State of LSP in American Higher Education: Reflecting on the First Decade of the ISLSP and Moving Forward”

Dr. Lourdes Sánchez-López, Founder of ISLSP, University of Alabama at Birmingham

Lourdes Sánchez-López, PhD. (Applied Linguistics, University of Jaén) is Professor of Spanish, Associate Department Chair, and Director of the Spanish for Specific Purposes program in the Department of Foreign Languages and Literatures, University of Alabama at Birmingham. Dr. Sánchez-López organized and directed the I International Symposium on Languages for Specific Purposes (University of Alabama at Birmingham, 2012). The I ISLSP helped launch a national and international collaborative movement of LSP scholars in the US and beyond, setting the path for a series of critical developments in LSP teaching and learning, and scholarship in American higher education. She is the editor of *Scholarship and Teaching on Languages for Specific Purposes* (UAB Digital Collections, 2013), a volume with selected peer-reviewed articles inspired by concepts discussed at the I ISLSP. She is also co-author of two Spanish textbooks, *El mundo hispanohablante contemporáneo: Historia, política, sociedades y cultura* (*The Contemporary Spanish-Speaking World: History, Politics, Societies, and Culture*) (Routledge, 2016), and *Pueblos, Intermediate Spanish in Cultural Contexts* (Cengage, 2006). Dr. Sánchez-López has authored and co-authored numerous scholarly articles and book chapters in LSP nationally and internationally.



Next Generation LSP Scholars 2020

The 5th International Symposium on Language for Specific Purposes (ISLSP) and the Centers for International Business Education and Research (CIBER) Business Language Conference hosted by UNC Charlotte are very pleased to inaugurate the Next Generation LSP Scholars Registration Waiver program to help support graduate students and their studies of languages for specific purposes. By attending and participating in the conference, qualified graduate students are able to engage in LSP scholarly research discussions, meet and network with peers, faculty and editors who are working and publishing in LSP, and share their own LSP ideas and projects. The purpose of the Next Generation LSP Scholars Registration Waiver program is to support the health and growth of LSP studies, the conference, and up-and-coming researchers and teachers in the field.

Congratulations to our **Next Generation LSP Scholars 2020!**

- Aisye Demir, University of South Carolina
- Audrey Chery, Arizona State University
- Joanna Orozco, University of Memphis
- Jonathan Jones-Edwards, University of Memphis
- Kichan Park, University of Maryland College Park
- Laura Price, University of North Carolina at Charlotte
- Maria García, University of North Carolina at Charlotte
- Mariele Cunha de Souza, University of Memphis
- Sean Hill, Central Michigan University
- Xinyue Lu, Ohio State University
- Priscila J.B.M. Costa, University of South Carolina

CIBER Business Language, Research and Teaching (BLRT) Awards

In order to encourage faculty, lecturers and graduate students in foreign language departments to add a business-language dimension to their research and teaching, the 17 Centers for International Business Education and Research (CIBERs) have pledged a portion of their Title VI CIBER grant funding to support the Business Language Research and Teaching (BLRT) Awards.

Congratulations to the **2020 CIBER BLRT** recipients!

- **Sibel Crum**, Indiana University
- “Digital Technology Integrated Turkish Business Language Courses”
- **Wei Lai**, Queensborough Community College
- “Effects of Backward Instructional Design in an Advanced Business Chinese Course”
- **Hei Sook Yoo**, George Mason University
“Developing a Blended/Online Business Language Course for Career Readiness in the 21st Century”

PRESENTERS INDEX

Name	Institution	Email Address
Adrada Rafael, Sergio	Fairfield University	sadradarafael@fairfield.edu
Aguilar, Julio César	Baylor University	Julio_Aguilar@baylor.edu
Al-Ali, Ghayda	Georgetown University	ga411@georgetown.edu
Alsina Naudi, Anna	Princeton University	aalsina@princeton.edu
Amling, Stacy	Des Moines Area Comm. College	slamling@dmacc.edu
Baker, Lottie	George Washington University	lottie@gwu.edu
Balcells, José María	Universidad de León	jmbald@unileon.es
Banerjee, Erika	UNC Charlotte	ebanerje@uncc.edu
Barrett, Joan	Baylor University	Joan_barrett@baylor.edu
Barton, Paige	Ohio State University	barton.353@osu.edu
Becher, Anne	University of Colorado Boulder	anne.becher@colorado.edu
Becker, Klaus	Honorary Consul to Germany	klaus.becker@nirosteel.com
Bergeson, Craig	Weber State University	cbergeson@weber.edu
Bouche, Hélène	Embassy of France	helene.bouche@diplomatie.gouv.fr
Braden, Allison	UNC Charlotte	abraden1@uncc.edu
Brady, Jennifer	University of Minnesota Duluth	jnbrady@d.umn.edu
Brautlacht, Regina	Bonn-Rhein-Sieg U. of Applied Sciences	regina.brautlacht@h-brs.de
Buckley, Paola	Southern Methodist University	pbuckley@smu.edu
Burgos, Diego A.	Wake Forest University	burgosda@wfu.edu
Carter, Beverly-Anne	UWI St Augustine Campus Trinidad & Tobago	Beverly-Anne.Carter@sta.uwi.edu
Ciesco, Nathalie	University of Florida	nciesco@ufl.edu
Ciller, Julio	UTRGV	julio.ciller@utrgv.edu
Crum, Sibel	Indiana University Bloomington	ari.sibel@gmail.com
Cunha de Souza, Mariele	University of Memphis	mlcnhdsz@memphis.edu
Cunico dal Pra, Daniela	UNC Charlotte	dcunicod@uncc.edu
Daniélou, Catherine	U. of Alabama at Birmingham	danielou@uab.edu
Demir, Asiye	University of South Carolina	ademir@email.sc.edu
Doyle, Michael	UNC Charlotte	msdoyle@uncc.edu
Drewelow, Isabelle	University of Alabama	idrewelow@ua.edu
Esseesy, Mohssen	George Washington University	esseesym@gwu.edu
Ferrell, Lee	Clemson University	ferrell@clemson.edu
Fu, Liang	Rice University	lf4@rice.edu
Gasca Jiménez, Laura	Fairfield University	lgascajimenez1@fairfield.edu
Gasta, Chad	Iowa State University	gasta@iastate.edu
Godev, Concepción	UNC Charlotte	cgodev@uncc.edu
Gonglewski, Margaret	George Washington University	margaret@gwu.edu
Gorke, Yongling	UNC Charlotte	ygorke@uncc.edu
Gray, Lee	UNC Charlotte	legray@uncc.edu
Grim, Frédérique	Colorado State University	Frederique.Grim@colostate.edu
Haimovich, Gregory	University of Warsaw	grhaimovich@al.uw.edu.pl
Hanson, Thomas	Butler University	thanson3@kent.edu
Hardin, Karol	Baylor University	karol_hardin@baylor.edu
Helguero-Balcells, Graciela	NOVA Southeastern U./NVCC	gracielaHB@aol.com
Helm, Anna	George Washington University	ahelm@gwu.edu

Hill, Sean	Grand Valley State University	seanhill@delta.edu
Holle, Alexandre	CCI Paris Ile-de-France	aholle@cci-paris-idf.fr
Hoult-Saros, Stacy	Valparaiso University	Stacy.Hoult-Saros@valpo.edu
Huang, Teh-yi	Weber State University	chinese.dori@gmail.com
Huempfer, Lisa	UW-Whitewater	huempfnl@uww.edu
Hulme, Wendi	Conestoga College ITAL	whulme@conestogac.on.ca
Hunt, Hannah	Christopher Newport University	Hannah.hunt.09@cnu.edu
Irom, Allyson	Baylor University	Allyson_Irom@baylor.edu
Jakeway, Angela	UNC Charlotte	ajakeway@uncc.edu
Jones, Cynthia	Weber State University	cynthiajones1@weber.edu
Jones-Edwards, Jonathan	University of Memphis	jjsndwr@memphis.edu
Julian, Kristi	Middle Tennessee State U.	kristi.julian@mtsu.edu
Kanost, Laura	Kansas State University	lakanost@ksu.edu
Killman, Jeffrey	UNC Charlotte	jkillman@uncc.edu
King de Ramirez, Carmen	University of Arizona	carmenking@email.arizona.edu
Korshunova, Svetlana	Princeton University	sk22@princeton.edu
Lafford, Barbara	Arizona State University	blafford@asu.edu
Lai, Wei	Queensborough Community College	wlai@qcc.cuny.edu
Lank, Steve	Cesco Linguistic Services Inc.	slank@cescols.com
Lear, Darcy	University of Chicago	darcylear@gmail.com
Lebaudy, Geraldine	University of Pennsylvania	lebaudyg@sas.upenn.edu
Li, Shuai	Georgia State University	sli12@gsu.edu
Liu, Meiru	Lewis & Clark College	liu@lclark.edu
Long, Mary K	University of Colorado Boulder	mary.long@colorado.edu
Lozano Bachioqui, Eleonora	U. Autónoma de Baja California	eleonoralozano@uabc.edu.mx
Lu, Xinyue	Ohio State University	lu.2092@osu.edu
Magaña, Dalia	University of California Merced	dmagana6@ucmerced.edu
Mahaffey, Maria	UNC Charlotte	memahaff@uncc.edu
Makhoul, Duaa	Greensboro College	dmakhoul89@gmail.com
Malcolm, Karen	University of Colorado Boulder	karen.malcolm@colorado.edu
Martinez, Glenn	Ohio State University	martinez.474@osu.edu
McCoy, Heather	Pennsylvania State University	hjm10@psu.edu
Medrado Costa, Priscila	University of South Carolina	priscila@email.sc.edu
Mellinger, Christopher	UNC Charlotte	cmelling@uncc.edu
Merfeld-Langston, Audra	Missouri U. of Science & Technology	audram@mst.edu
Meyer, E. Nicole	Augusta University	nimeyer@augusta.edu
Moraga, Veronica	University of Chicago	vmoraga@uchicago.edu
Moreland, Greg	University of Florida	moreland@ufl.edu
Moscardo-Valles, Paloma	Princeton University	moscardo@princeton.edu
Musgrove, Jennifer	Iowa State University	musgrove@iastate.edu
Myers, Megan	Iowa State University	mjmyers@iastate.edu
Nagle, Charles	Iowa State University	cnagle@iastate.edu
Naranjo, Andrea	Clemson University	anaranj@clemson.edu
Nekrasova-Beker, Tatiana	Colorado State University	t.nekrasova_beker@colostate.edu
Orozco, Joanna	University of Memphis	jorozco1@memphis.edu
Park, Kichan	University of Maryland at College Park	navyet60@gmail.com

Peckenpaugh, Kacy	Weber State University	kacypeckenpaugh@weber.edu
Peebles, Kelly	Clemson University	kpeeble@clemson.edu
Pérez, María E.	Retired. University of Houston	meptx98@hotmail.com
Pérez, Oscar A.	Skidmore College	operezhe@skidmore.edu
Pérez-Muñoz, Carmen	Wake Forest University	perezmc@wfu.edu
Petrashova, Tamara	Tomsk Polytechnic University	petrashova@tpu.ru
Pinillos Chavez, Paloma	Ohio State University	pinilloschavez.1@osu.edu
Poveda Moreno, Esther	University of Virginia	mp8yk@virginia.edu
Purdy, Andrea	Colorado State University	Andrea.Purdy@colostate.edu
Reaves, Alisha	University of Notre Dame	areaves@nd.edu
Redmon, Maria	University of Central Florida	maria.redmon@ucf.edu
Reisinger, Deborah	Duke University	debsreis@duke.edu
Risner, Mary	University of Florida	mriskner@latam.ufl.edu
Rivers, Bill	JNCL-NCLIS	writers@languagepolicy.org
Rodríguez-Castro, Mónica	UNC Charlotte	monica.rodriguez@uncc.edu
Rubio, Christian	Bentley University	crubio@bentley.edu
Ruggiero, Diana	University of Memphis	dianaruggiero@gmail.com
Sack, William	United States Military Academy	william.sack@westpoint.edu
Sales DeSouza, Ismenia	US Air Force Academy	Ismenia.desouza@usafa.edu
Sánchez-López, Lourdes	U. of Alabama at Birmingham	lourdes@uab.edu
Santamaria Laorden, Natalia	Ramapo College of New Jersey	nsantama@ramapo.edu
Sarver, Isaac	Michigan State University	sarveri@msu.edu
Shanker, Sandhya	Michigan State University	shankers@msu.edu
Sheffer, Amanda	Catholic University of America	sheffer@cua.edu
Shi, Zhongqi	Columbia University	zs2132@columbia.edu
Spaine Long, Sheri	AATSP	spainelong@aatsp.org
Sprague, Paula	University of Virginia	pas6ea@virginia.edu
Takeuchi, Jae	Clemson University	jtakeuc@clemson.edu
Tissera, Graciela	Clemson University	gtisser@clemson.edu
Utrilla, David	Honorary Consul to Peru	david@ustranlation.com
Vásquez, Félix	College of Charleston	vasquezf@cofc.edu
Velazquez-Castillo, Maura	Colorado State University	mvelaz@colostate.edu
Verlinden, Marianne	College of Charleston	verlindenm@cofc.edu
Victor, David	Eastern Michigan University	dvictor@emich.edu
Vincent, Amanda	Wake Forest University	vincenas@wfu.edu
Waldvogel, Dieter	AATSP	dwaldvogel@aatsp.org
Watson, Maida	Florida International University	javenda@fiu.edu
Wooten, Adam	Middlebury ISS	awooten@middlebury.edu
Wyatt, Shelly	University of Central Florida	Shelly.Wyatt@ucf.edu
Yeh, Meng	Rice University	myeh@rice.edu
Yoo, Hei Sook	George Mason University	hyoo6@gmu.edu
Young, Michael	Appalachian State University	youngmn2@appstate.edu
Yu, Qiaona	Wake Forest University	yuq@wfu.edu
Zeller, Shannon	Colorado State University	shannon.zeller@colostate.edu
Zmurkewycz, U. Theresa	St. Joseph's University	tzmurkew@sju.edu

SPONSORS

We would like to thank our sponsors for their generous support of the 5th ISLSP/CIBER Business Language Conference.

Centers for International Business Education Department of Education

**Brigham Young University
Florida International University
George Washington University
Georgia Institute of Technology
Georgia State University
Indiana University
Loyola Marymount University
Michigan State University**

**San Diego State University
Temple University
Texas A&M University
University of Colorado-Denver
University of Maryland
University of South Carolina
University of Washington
U.S. Department of Education**



Centers For International Business Education & Research

University of North Carolina at Charlotte



UNC CHARLOTTE

**College of Liberal Arts and Sciences
Office of International Programs
College of Arts + Architecture
Department of Global Studies
Latin American Studies
Department of Languages and Culture Studies**

**The Graduate School at UNC Charlotte
Confucius Institute at UNC Charlotte
Belk College of Business
University Career Center
Department of English**



Translation and Interpreting Studies
